

VAL-SQ SP 80-120/240S/FM

Order No.: 2804000

<http://eshop.phoenixcontact.de/phoenix/treeViewClick.do?UID=2804000>

Surge protection device for 120/240 V AC split/single phase configurations. Uses a compact, NEMA rated enclosure that connects easily to an existing enclosure. Hybrid Sine Wave Tracking provides 80 kA surge protection.

Commercial data	
EAN	4046356317122
Pack	1 pcs.
Customs tariff	85363030
Weight/Piece	2.883 KG

<http://www.download.phoenixcontact.com>
Please note that the data given here has been taken from the online catalog. For comprehensive information and data, please refer to the user documentation. The General Terms and Conditions of Use apply to Internet downloads.

Product description

Surge protection device for 120/240 V AC single/split phase configurations with 80 kA protection

Technical data

Standards	
Degree of protection	IP40 / NEMA 1
Mounting type	3/4 inch NPT male
Design	Parallel hybrid
Ambient temperature (operation)	-40 °C ... 60 °C
Ambient temperature (storage/transport)	-40 °C ... 85 °C
Altitude	3658 m

Message surge protection faulty	Phase LEDs
	Audible alarm
	Remote indicator contact
Direction of action	3L-N & N-GND
Width	250.00 mm
Height	122.00 mm
Length	79.00 mm

Protective circuit

IEC category	I
Arrester rated voltage U_c	150 V
Response time	< 1 ns

Connection, protective circuit

Type of connection	#10 AWG/5.26 mm ² wires (24 in./61 cm long)
Connection method	3-wire + Gnd
Conductor cross section AWG/kcmil min.	10
Conductor cross section AWG/kcmil max	10

Remote indicator contact

Type of connection	#24 AWG/0.205 mm ² wires (24 in./61 cm long)
--------------------	---

Environmental conditions

Standards/regulations	UL 1449 2 nd edition, February 2007
	UL 1283
	IEEE C62.41
	IEEE C62.45

NEMA / UL data

NEMA / UL data	type 2
short circuit current rating (SCCR)	22 kA
UL type	type 2
Voltage (L-L)	800 V
Voltage (N-G)	400 V
Voltage (L-G)	500 V
Voltage (L-N)	400 V
Maximum Circuit Breaker	30 A
Maximum Surge Current per Phase	80 kA

Drawings

Circuit diagram

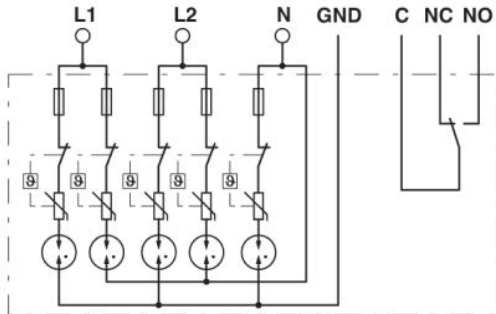

Address

PHOENIX CONTACT GmbH & Co. KG
Flachmarktstr. 8
32825 Blomberg, Germany
Phone +49 5235 3 00
Fax +49 5235 3 41200
<http://www.phoenixcontact.com>



© 2009 Phoenix Contact
Technical modifications reserved;